

drive**DeVilbiss**
HEALTHCARE

Rise Sit to Stand

OWNER'S MANUAL**REF PR51STSP**

DEALER: This manual must be given to the user of the patient lift.

USER: Before using this patient lift, read this manual and save for future reference.

SERVICE AGENT: Only Drive DeVilbiss Healthcare authorised service agents are permitted to service or repair the Rise Sit to Stand product.

TABLE OF CONTENTS

BASIC INFORMATION.....	3
STANDARD SYMBOLS USED IN THIS MANUAL.....	5
GENERAL SAFETY.....	7
DECLARATION - ELECTROMAGNETIC EMISSIONS.....	11
FEATURES AND BENEFITS.....	14
TECHNICAL SPECIFICATIONS.....	15
GENERAL INFORMATION.....	18
SLING COMPATIBILITY.....	19
OPERATION.....	23
BATTERY INFORMATION.....	32
CARE AND MAINTENANCE.....	34
SERVICING.....	36
WARRANTY.....	39
END OF LIFE DISPOSAL.....	40

BASIC INFORMATION

Product Name: Rise Sit to stand

Model:PR51STSP

Application Scope:

The lift is a battery powered, mobile electric rise sit to stand intended for individuals at home, hospital and institutional healthcare environment use. The Rise Sit to Stand is for indoor use only.

Intended purpose:

To assist in the transfer of a user from a seated to a standing position and as necessary back to a seated position.

Intended users

Users who have good upper body stability and have some weight bearing capacity but needs assistance when standing. User who is up to 204 kg.

Indications

To provide mobility to a user who has difficulty standing and/or lowering to a seated position due to an injury, physical disability or medical condition.

Contra-indications

- Users of the lift whose mental capacity is not sufficient to operate the lift safely.
- Patient unable to weight bear
- Patient has weak grip
- Patient exceeds maximum patient weight

Other contraindications may be relevant which are specific to the individual and/or environment of use.)

Note: *The caregiver must only use two hooks at one time and they must be on the same level. The furthest two hooks are for a shorter person, closer hooks are for a taller person.*

Date of manufacture: See package

Expected lifetime of the product: 5 years

Weight Capacity: 204 kg

Power/Manual Base: Power

Structure:

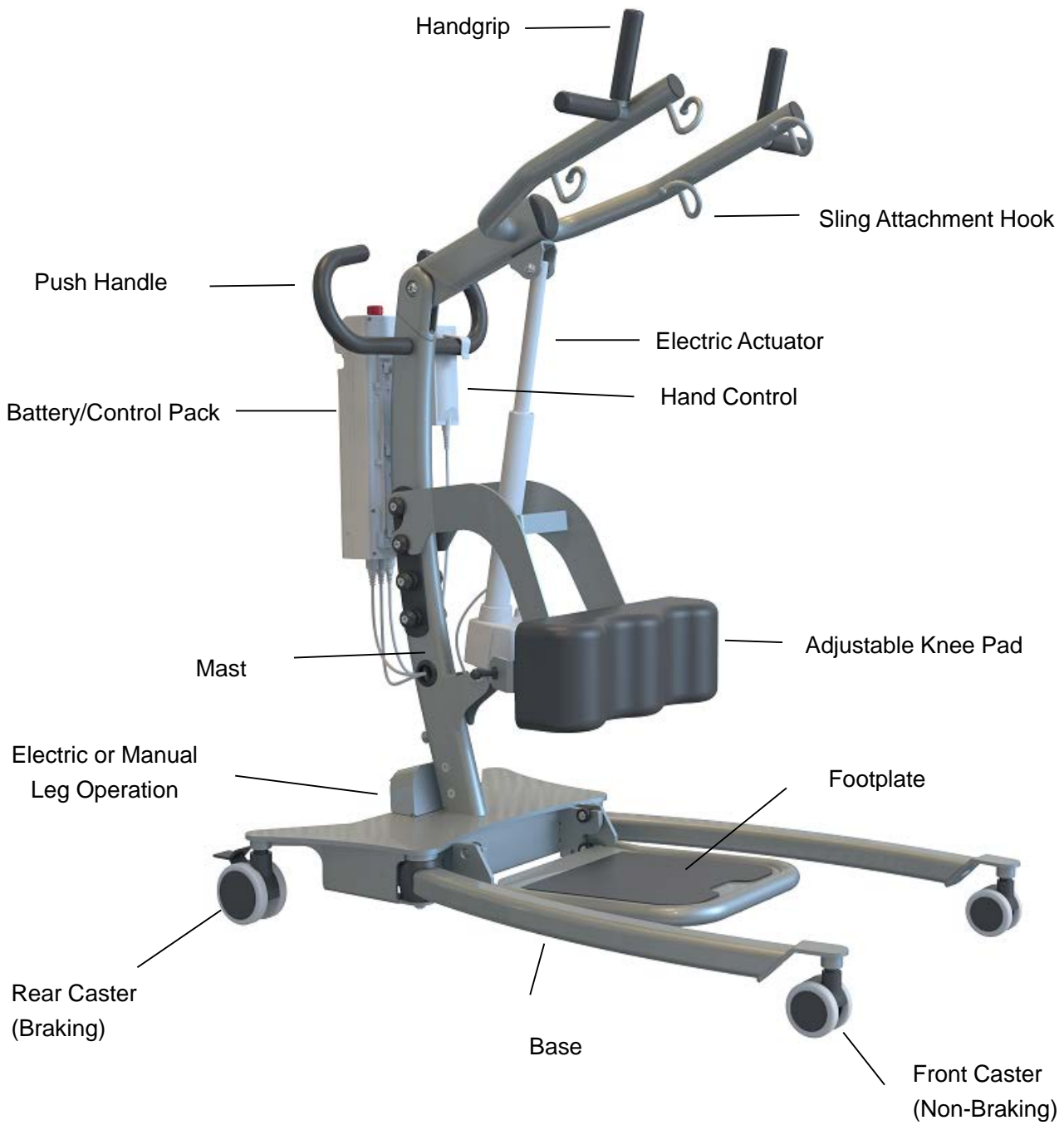



WARNING

- Training: all individuals operating the lift are to be suitably familiar with the functionality and limitations prior to use.
- It is the responsibility of the user to ensure they are suitably trained to use the lift and any associated accessories safely and correctly. If these instructions for use are not deemed sufficient and the need for training is required, please contact Drive DeVilbiss Healthcare Ltd. or your local provider who can discuss training options with you.
- If a serious incident occurs, the provider and local competent authority should be contacted immediately.

STANDARD SYMBOLS USED IN THIS MANUAL

NOTE: *This manual includes important information about the safety of personnel and equipment. As you read through this manual be aware of the symbols and their meanings.*



DANGER

Information that appears under the DANGER symbol concerns the protection of personnel from direct and pending hazards that, if not avoided, will result in immediate, serious personal injury or death in addition to damage of the equipment.



DANGER SHOCK HAZARD

Information that appears under the DANGER SHOCK HAZARD symbol concerns the protection of personnel from possible hazards related to electrical shock.



FIRE HAZARD

Information that appears under the FIRE HAZARD symbol concerns the protection of personnel from possible hazards related to fire and flammability.



WARNING























Information that appears under the WARNING symbol concerns the protection of personnel from possible hazards that can result in injury or death in addition to damage of the equipment.

Information that appears under the WARNING symbol concerns the protection of personnel from possible hazards that may result in minor injury or damage of the equipment.

- NOTE:

Information that appears with the NOTE text gives added information, which helps in understanding the item being described.

Graphs and symbols used for medical device labels:

	Type BF applied part equipment.		CE marking in conformity with Regulation (EU)2017/745
	In conformity with regulation UK MDR 2002		Manufacturer
	Date of manufacture		Medical Device
	Authorised Representative in the European Community	 	Indicates the need for the user to consult the instructions for use for important cautionary information such as warnings and precautions that cannot, for a variety of reasons, be presented on the medical device itself.
UKRP	UK responsible person		
	Serial number:		Indicates the range of humidity to which the medical device can be safely exposed.
	Refer to instruction manual/booklet:		Catalogue number: To identify the manufacturer's product code
	Importer		Disposal of Waste electrical and electronic equipment (WEEE) – see page 41
	Maximum safe working load.		For indoor use only.
	Heavy Object: Take care when lifting	IP24	This lift is identified as equipment that is protected against solid foreign objects of 12.5 mm and greater and splashing water.
	Temperature limit: To identify the temperature limits		Atmospheric pressure limitation: To indicate the acceptable upper and lower limits of atmospheric pressure for transport and storage.
	For indoor use only : To identify electrical equipment designed primarily for indoor use.		Class II electrical equipment: The user/occupant is protected by at least two layers of insulation.

 + = 271kg
(597lbs)

Combined mass of the lift and its safe working load

GENERAL SAFETY



WARNING

- Consideration is to be taken in the positioning of the lift, handset and charger cables to minimise the risk of accidental strangulation resulting from entanglement by a child or an adult who has a reduced mental capacity.
- Check all parts for shipping damage before using. In case of damage, DO NOT use the equipment. Contact the Drive DeVilbiss Healthcare for further instructions.
- DO NOT operate this lift without first reading and understanding the warnings, cautions and instructions in this manual. If you are unable to understand the warnings, cautions, and instructions, contact a healthcare professional, dealer or technical personnel if applicable before attempting to use this lift-otherwise injury or damage may result.
- This Drive DeVilbiss Healthcare patient lift may be safely operated by a single appropriately trained and experienced caregiver. However, there are circumstances (including but not limited to the patient's medical, psychological or behavioral condition, as well as the caregiver's training, experience or physical limitations) that may require two people to safely operate the lift. It is the responsibility of each facility or caregiver to determine if more than one person is required to safely operate the lift at the time of transfer, depending on these circumstances. It is also the responsibility of each facility or caregiver to ensure that the lift is only operated without additional assistance, if circumstances safely allow, by someone who: (1) has thoroughly studied the instructions for use for both the lift and any accessories; (2) has adequate training and experience to determine that the lift may be safely operated without additional assistance; and (3) can operate the lift without assistance.
- DO NOT use the sling in combination with the lift as a transport device. It is intended to transfer an individual from one resting surface to another (such as a bed to a wheelchair).
- DO NOT attempt any transfer without approval of the patient's Medical Practitioner, nurse or medical assistant. Thoroughly read the instructions in this Instruction manual, observe a trained team of experts perform the lifting procedures and then perform the entire lift procedure several times with proper supervision and a capable individual acting as a patient.
- Individuals that use the sling MUST be able to support the majority of their own weight, otherwise injury can occur.
- DO NOT exceed maximum weight limitation of the Lift. The maximum weight limitation is 204 kg. regardless of any additional weight limitations on accessories.

- DO NOT raise the patient to a full standing position while using the sling otherwise injury can occur.
- When lifting the patient, make sure the base legs are opened to their widest position and the rear casters are unlocked. Otherwise, the lift may tilt over.
- Before positioning the legs of the lift around the patient, make sure the patient's feet are out of the way of the footplate, otherwise injury can occur.
- Drive DeVilbiss Healthcare have a range of slings and accessories designed for use with the Rise Sit to Stand. Other manufacturers slings can be used but it is the user's responsibility to ensure they are compatible. For queries regarding compatibility please contact Drive DeVilbiss Healthcare or your provider. Drive DeVilbiss Healthcare accepts no liability for incorrect use of slings or accessories.
- ALWAYS check the sling is suitable for the particular patient and is of the correct size and capacity.
- Before lifting the patient, make sure the bottom edge of the sling is positioned on the lower back of the patient and the patient's arms are outside the sling.
- The belt of the sling MUST be snug, but comfortable on the patient, otherwise the patient can slide out of the sling during transfer, possibly causing injury.
- ENSURE sling loops are pulled completely and are securely positioned on the hooks.
- NEVER use a sling which is frayed or damaged.
- When elevated a few inches off the surface being transferred from and before moving the patient, check again to make sure that the sling is properly connected to the attachment points of the lift. If any attachments are NOT properly in place, lower the patient back onto the surface and correct this problem.
- NEVER operate the lift with loose or missing parts or fasteners.
- Use the push handle on the mast at ALL times to push or pull the lift.
- DO NOT roll lift over deep carpet, raised carpet bindings or any uneven surfaces which may cause lift to lose its balance.
- DO NOT bump the lift down steps, loaded or unloaded.
- DO NOT push a loaded lift at speeds which exceed a slow walking pace (2.6 ft/sec)
- DO NOT park a loaded lift on ANY sloping surface.
- DO NOT use or store in a wet or corrosive environment: shower, bath or pool locations.
- DO NOT attempt to negotiate a slope without a second helper being present.
- Push the "Emergency" red button if the control unit system is out of control.
- DO NOT attempt to negotiate a loaded lift on a slope, which exceeds 1:12 (approx. 5 degrees)
- The battery must be connected to an appropriate power source when loss of power source would result in an unacceptable risk.

- DO NOT charge batteries in a bathroom or shower room.
- DO NOT place or store batteries under direct sunlight or near a heat source.
- DO NOT allow children or pets to climb or play with the device.
- Maintenance **MUST** be performed **ONLY** by authorised, competent personnel.
- Regular maintenance of the Lift and accessories is necessary to assure proper operation.
- Do not modify this lift without authorisation of the manufacturer. If unauthorised service is performed on any components the warranty is void.
- Direct sunlight leading to increased surface temperature of the frame.



DANGER SHOCK HAZARD

- DO NOT roll the lift over any power or handset cables.
- DO NOT open any actuators, control boxes, handset or battery. Service and repair must only to be performed by authorised service personnel. If unauthorised service is performed on any components the warranty is void.
- DO NOT allow the cables, electrical outlets, and electrical control box or hand handset to become wet or submerged.
- DO NOT operate the lift if any electrical component such as the electrical outlet, connections, motor/actuator, battery or mechanical component has malfunctioned or has been damaged in any way.
- To avoid risk of electric shock, this equipment must only be connected to supply mains with protection earth when charging.



FIRE HAZARD

- DO NOT use near open flame or explosive gases.
- This lift should not be placed in an oxygen enriched environment.



WARNING

- Drive DeVilbiss Healthcare recommends locking the rear swivel casters **ONLY** when positioning or removing the sling from around the patient.
- Drive DeVilbiss Healthcare does **NOT** recommend locking the rear swivel casters of the lift when lifting and transferring an individual. Doing so could cause the lift to tip and endanger the patient and carer. Drive DeVilbiss Healthcare does recommend that the rear swivel casters be left unlocked during lifting and transferring procedures to allow the lift to stabilize itself when the patient is initially lifted from and transferred to

a chair, bed or any stationary object.

- Pinch Points: Feet and hands could be pinched. Keep feet and hands away from the pinch points.

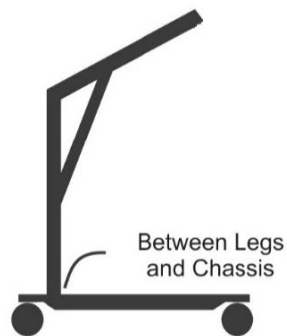

ELECTROMAGNETIC EMISSION AND IMMUNITY

- This MEDICAL ELECTRICAL EQUIPMENT needs special precautions regarding EMC and needs to be installed and put into service according to the EMC information provided in the table below.
- Portable and mobile RF communications equipment can affect MEDICAL ELECTRICAL EQUIPMENT.
- This lift frame complies with EMC requirements of IEC 60601-1-2. Radio transmitting equipment, cell phones or similar electronic devices, used in proximity of the lift, may affect the lifts performance.



WARNING

The use of ACCESSORIES, transducers and cables other than those specified, with the exception of transducers and cables sold by the manufacturer of the EQUIPMENT or SYSTEM as replacement parts for internal components, may result in increased EMISSION or decreased IMMUNITY of the EQUIPMENT or SYSTEM.



WARNING

The ME EQUIPMENT or SYSTEM should not be used adjacent to or stacked with other equipment and that if adjacent or stacked use is necessary, the ME EQUIPMENT or SYSTEM should be observed to verify normal operation in the configuration in which it will be used.

DECLARATION - ELECTROMAGNETIC EMISSIONS

Guidance and manufacturer's declaration - Electromagnetic emissions		
<p>The Rise Sit to Stand PR51STSP is intended for use in the electromagnetic environment specified below. The customer or the user of the Rise Sit to Stand PR51STSP should ensure that it is used in such an environment.</p>		
Emissions Test	Compliance	Electromagnetic environment - Guidance
RF Emissions CISPR 11	Group 1	<p>The Rise Sit to Stand PR51STSP uses RF energy only for its internal function. Therefore, its RF emissions are very low and are not likely to cause any interference in nearby electronic equipment.</p>
RF Emissions CISPR 11	Class B	
Harmonic Emissions IEC 61000-3-2	Class A	<p>The Rise Sit to Stand PR51STSP is suitable for use in all establishments including domestic establishments and those directly connected to the public power supply network that supplies buildings used for domestic purposes.</p>
RF emissions CISPR 14-1	Complies	<p>The Rise Sit to Stand PR51STSP is not suitable for interconnection with other equipment.</p>
RF emissions CISPR 15	Complies	

Recommended separation distances between portable and mobile RF communications equipment and the Prime Care™PR51STSP			
<p>The Rise Sit to Stand PR51STSP is intended for use in the electromagnetic environment in which radiated RF disturbances are controlled. The customer or the user of the Rise Sit to Stand PR51STSP can help prevent electromagnetic interference by maintaining a minimum distance between portable and mobile RF communications equipment (transmitters) and the Rise Sit to Stand PR51STSP as recommended below, according to the maximum output power of the communications equipment.</p>			
Rated maximum output power	Separation distance according to frequency of transmitter m		
	150 kHz to 80 MHz	150 kHz to 80 MHz	800 MHz to 2,5 GHz
	$d=(1,2 \sqrt{P})$	$d=(1,2 \sqrt{P})$	$d=(2,3 \sqrt{P})$

of transmitter W			
0.01	0.12	0.12	0.23
0.1	0.38	0.38	0.73
1	1.2	1.2	2.3
0.1	0.38	0.38	0.73
10	3.8	3.8	7.3
100	12	12	23

For transmitters rated at a maximum output power not listed above, the recommended separation distance d in meters (m) can be estimated using the equation applicable to the frequency of the transmitter, where P is the maximum output power rating of the transmitter in watts (W) accordable to the transmitter manufacturer.

NOTE1: At 80 MHz and 800 MHz the separation distance for the higher frequency range applies

NOTE2: These guidelines may not apply in all situations. Electromagnetic propagation is affected by absorption and reflection from structures, objects and people.

Guidance and manufacturer's declaration: Electromagnetic Immunity

The Rise Sit to Stand PR51STSP is intended for use in the electromagnetic environment specified below. The customer or the user of the Rise Sit to Stand PR51STSP should ensure that it is used in such an environment.

Immunity test	IEC 60601 test level	Compliance level	Electromagnetic environment - guidance

<p>Conducted RF IEC 61000-4-6</p>	<p>3 Vrms 150 kHz to 80 MHz</p>	<p>10 V</p>	<p>Portable and mobile RF communications equipment should be used no closer to any part of the Rise Sit to Stand PR51STSP, including cables, than the recommended separation distance calculated from the equation applicable to the frequency of the transmitter.</p>
<p>Radiated RF IEC61000-4-3</p>	<p>3 V/m 80 MHz to 2.5 GHz</p>	<p>10 V/m</p>	<p>Recommended separation distance</p> $d = \left(\frac{3,5}{10}\sqrt{P}\right)$ <p>$d = \left(\frac{3,5}{10}\sqrt{P}\right)$ 80MHz to 800MHz</p> <p>$d = \left(\frac{7}{10}\sqrt{P}\right)$ 800MHz to 2,5GHz</p> <p>Where <i>P</i> is the maximum output power rating of the transmitter in watts (W) according to the Transmitter manufacturer and <i>d</i> is the recommended separation distance in meters (m). Field strengths from fixed RF transmitters, as determined by an electromagnetic site survey,^a should be less than the compliance level in each frequency range.^b</p> <p>Interference may occur in the vicinity of equipment marked with the following symbol:</p> 

NOTE1: At 80MHz and 800MHz the higher frequency range applies.

NOTE2: These guidelines may not apply in all situations. Electromagnetic propagation is affected by absorption and reflection from structures, objects and people.

a) Field strengths from fixed transmitters, such as base stations for radio (cellular/cordless) telephones and land mobile radios, amateur radio, AM and FM radio broadcast and TV broadcast cannot be predicted theoretically with accuracy. To assess the electromagnetic environment due to fixed RF transmitters, an electromagnetic site survey should be considered. If the measured field strength in the location in which the Rise Sit to Stand PR51STSP, is used exceeds the applicable RF compliance level above, the Rise Sit to Stand PR51STSP, should be observed to verify normal operation. If abnormal performance is

observed, additional measures may be necessary, such as reorienting or relocating the Rise Sit to Stand PR51STSP.

b) Over the frequency range 150 kHz to 80 MHz, field strengths should be less than 10 V/m.

FEATURES AND BENEFITS

- Provides stable assistance in standing, transferring and toileting.
- Four sling attachment hooks enable the lift to accommodate a variety of sling designs.
- Extra-wide, non-skid footplate provides a stable base for foot positioning.
- Soft, padded adjustable leg support.
- Easy-roll 4" rear casters and 3" front casters ensures stability and easy maneuverability over a variety of surfaces.
- 24V DC motor provides power and reliability.
- Motor has an emergency stop button and manual lowering feature.
- Visual battery charge indicator on hand control.
- Audible alert if the lift has low battery power.
- Can be charged on or off the lift.
- Includes removable, rechargeable battery (Figure A), wall mount charger (Figure B) and external charging cradle (Figure C) (optional).
- Smart/Safety control module.
- LCD Display and maintenance feature.
- Redundant controls.
- Overload capacity.

Lift Serial Numbers

When ordering parts or when contacting Drive DeVilbiss Healthcare Customer Service Department please include the lift's model and serial numbers, found on the identification labels as below. The identification labels are located on the legs of lift base.

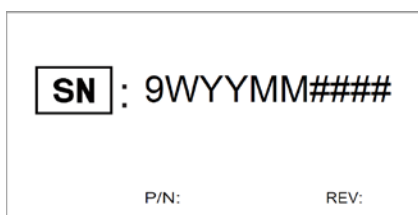

TECHNICAL SPECIFICATIONS

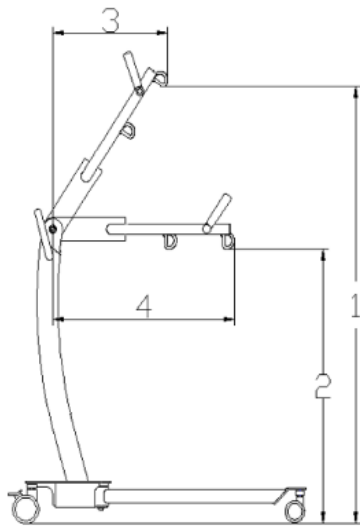

Lifting Range/Reach

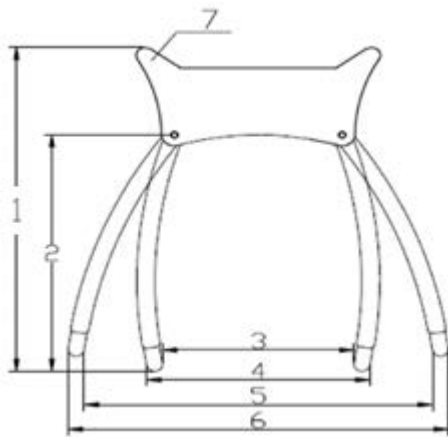

Base Height/clearance

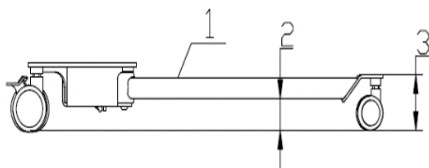

Base

Lifting Range/Reach (Unit: mm)			Base (Unit: mm)			Base height/clearance (Unit: mm)		
1	Max height of CSP	1664	1	Max external length	1069	1	Base	
2	Min height of CSP	960	2	Max internal length	780	2	Min clearance	69
3	Hoisting reach at Max height	152	3	Internal width when closed	546	3	Max height	120
4	Hoisting reach at Min height /Max lifting reach	692	4	External width when closed	635			
			5	Internal width when open	939			
			6	External width when open	1028			

ITEM	SPECIFICATION
Maximum Weight Capacity (SWL)	204 kg
Product Weight	67 kg
Castors	3" (Front) 4"(Rear)
Brakes	Yes – Rear
Charger Input	100 - 240 VAC,50/60 Hz, 0.5A
Charger Output	28 VDC, 0.8A
Maximum noise measured (sound level)	less than 65DB
Protective Earth Ground	Class II – no protective earth
Electrical Shock Protection	TYPE BF
Enclosure Protection	IP24
Duty cycle	Min. 2min (on)/ Max. 18min (off)
Motor Anti-Entrapment	Yes
Emergency Stop	Yes
Emergency Lowering	Yes
Battery Model	BAT
Battery Type	Lead-Acid
Battery Capacity	2.9 AH
Battery Input voltage	28.6VDC
Battery Output voltage	24V DC

The turning diameter: 1200mm

The mass of the heaviest detachable part of the lift: 37 kg

key dimensions of mobile lift (Unit: mm)

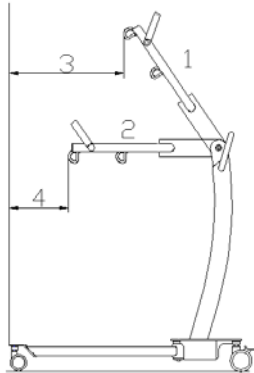

1. Highest position
2. Lowest position
3. Minimum distance from wall to CSP at the maximum height (leg spread): 810
4. Minimum distance from wall to CSP at the minimum height (leg spread): 270

PARTS AND MATERIALS

The following parts are included with the PR51STSP.

ITEM #	Description	Qty	ITEM #	Description	Qty
1	Boom	1	7	Manual	1
2	Mast	1	8	charger stand	1
3	Battery /Control Pack	1	9	Charger	1
4	Knee pad	1	10	Handset	1
5	Base	1	11	Hardware	1
6	Footplate	1			



GENERAL INFORMATION

The recommended environment for operation and storage/transportation of the lift is listed below:

	Operation	Storage/Transportation
Ambient temperature:	10°C ~ 36°C	-10°C ~ 50°C
Relative humidity range:	30% ~ 75%	20% ~ 95%
Atmospheric pressure:	86KPa~ 106Kpa	70KPa~ 106KPa

This lift is classified for intermittent operation. Lift may be operated for 2 minutes out of every 18 minutes.

APPLIED PARTS LIST

- Lift Frame
- Handset
- Handgrip
- Knee pad

MATERIALS ACCESSIBLE TO USER

- Surface Coating: Powder Coating
- Color of Powder: Grey
- Handset Housing: ABS
- Surface of Handgrip: PVC
- Surface of Knee pad: PU

SLING COMPATIBILITY

	Stand up sling	Transport sling
Small	3901BE	3901TBE
Medium	3902BE	3902TBE
Large	3903BE	3903TBE

- Please contact Drive DeVilbiss for any further information on the slings listed and for other slings within the Drive DeVilbiss range.
- It is the carer's responsibility for selecting and fitting the products correctly, ensuring that the product combination is compatible and a risk assessment has been carried out.

UNPACKING INSTRUCTIONS



CAUTION

Unpack the lift in an area with sufficient room to work. Do not allow patients near the lift until it has been completely set up and the work area has been cleared of all debris.

1. Inspect the lift for shipping damage. If the lift is damaged, do not use lift and immediately contact Drive DeVilbiss Healthcare for further instruction.
2. Verify the correct lift model was shipped. If you feel there was a mistake, do not use lift and immediately contact Drive DeVilbiss Healthcare for further instruction.
3. After verifying you've received the correct device without damage, cut strapping around box and remove enclosing lift.

NOTE: If the carton is in an upright position, slowly lower to the floor. It may be necessary for two or more people to help in lowering the lift.

4. Inspection of All Components - Receipt of assembled lift, the carton contains:
 - Sit to Stand Lift: Mast, Boom, Base, Footplate, Knee pad, Battery /Control Pack
 - Wallet containing documents
 - Handset
 - Charger.

ASSEMBLY

KNOWLEDGE/SKILLS REQUIRED

- Ability to read and understand the instruction for use
- Ability to manipulate required tools
- Basic mechanical aptitude

TOOLS REQUIRED

- Philips Screwdriver
- Allen Wrench 4, 5, 6, 8
- Adjustable Wrench



WARNING

- Installation **MUST** be performed **ONLY** by competent personnel.
- Avoid trapping fingers. Keep fingers away from the end of the mast when inserting into the base socket. Full engagement of the mast is indicated by the label on the side of the mast. The electric leg operation will not function unless the mast is fully engaged.

1. Remove all the parts from the carton and place on the floor, taking care to protect the finish from damage.

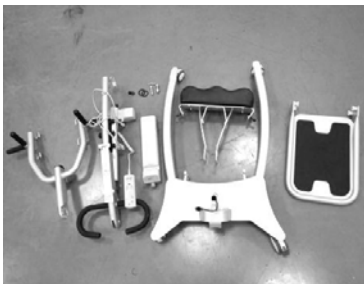

2. Place the base in a clear space and apply the rear brakes. If you are assembling a unit with a power base, connect the two power base connectors before sliding mast into base. Be careful to not damage the wire connectors.



3. Fit the mast into the base socket.

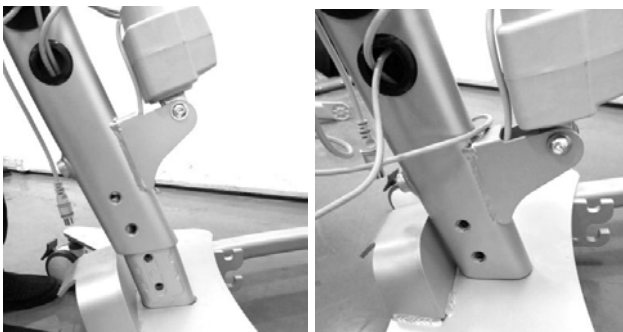

- Secure the mast to the base with four hex screws (M8x16) and one hex set screw (M6x12).

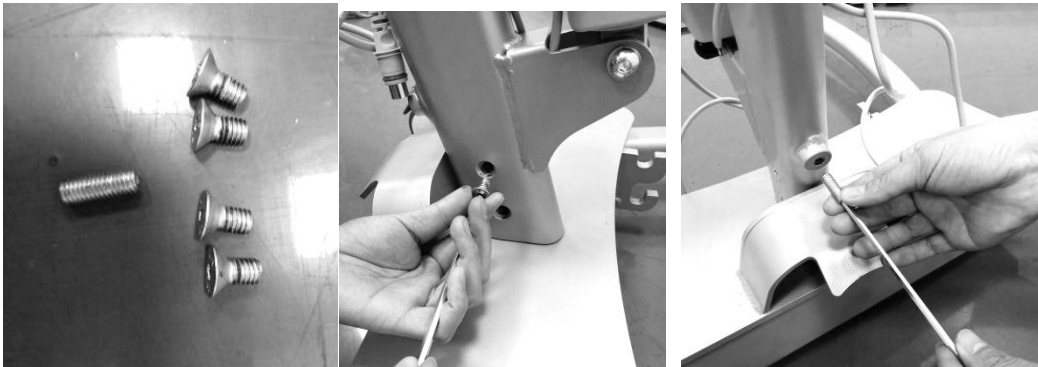

- Put one nylon gasket on each side of the boom end and fit the boom into the mast.

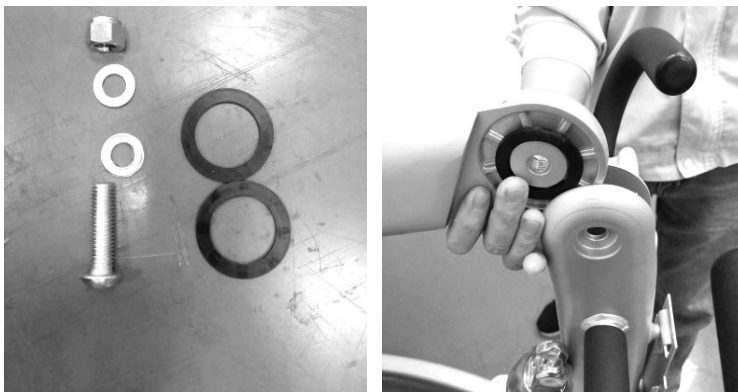

- Secure the boom to the mast with one hex bolt (M12x45).

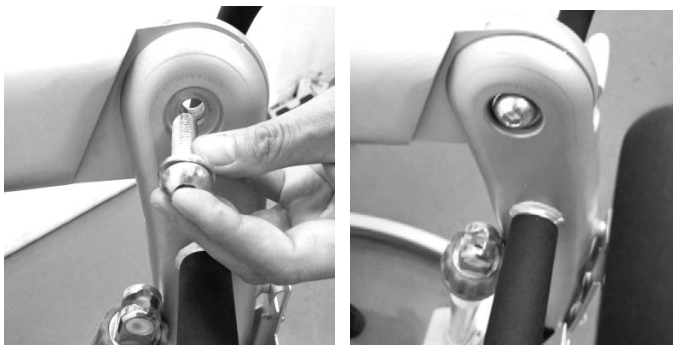

- Secure the lifting actuator to the boom with the hex bolt (M10x55).

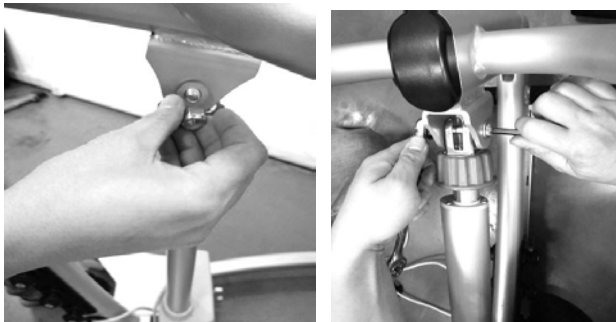

8. Install the control box onto the mounting bracket on the mast and tighten the control box with two mounting screws (M4).



9. Fit battery to control box and make sure the latch holding the battery in place is fully engaged "Click" in place.



10. Plug the handset and actuator cables into the socket located on the bottom side of control box. Refer to the figures below for correct positions.

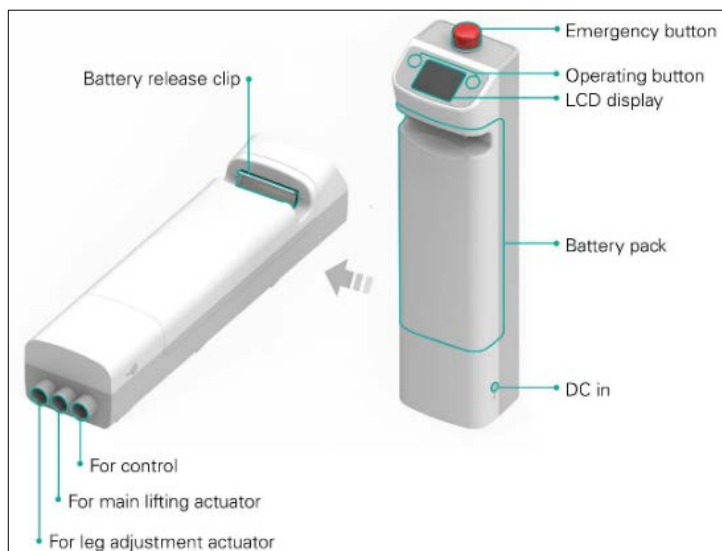
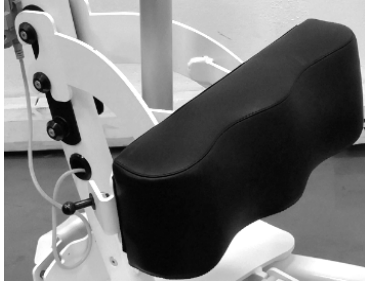

Figure D

11. Attach the footplate to the base



12. Attach the kneepad to the kneepad receiver



Note: The lift should not be disassembled unless for service, repair or transport if necessary. If disassembly is required, simply follow the assembly instructions in reverse sequence.

Note: Please always check the mast is fully locked into position.

OPERATION



WARNING

Always check the following before operation:

- The mast is fully locked into position.
- Confirm the boom rises and lowers (this is done via the hand control).
- The legs of the lift open and close satisfactorily (this is done via the hand control or shifter handle).
- Prior to first use, please make sure that the battery has been charged for 24 hours in order to function fully and prolong the lifetime of battery.

Locking/Unlocking the Rear Swivel Casters

- Locking - Press DOWN on the bottom of the locking lever.
- Unlocking - Press DOWN on the top of the locking lever.



Raising and Lowering the Lift

- Raising the lift -Press the (M1) UP button on the hand control to raise the lift arms and the patient.
- Lowering the lift -Press the (M1) DOWN button on the hand control to lower the lift arms and the patient.

NOTE: If the Lift is in the full UP position, it may be necessary to pull down slightly on the lift arms before the mast will lower.

Closing/Opening the Leg Base

Electric leg adjustment

- Opening the leg base- Pressing the (M2) left button widens the leg base;
- Closing the leg base-Pressing the (M2) right button closes the leg base.

Definitions: M1 -Actuators for Lifting; M2 -Actuators for Leg Adjustments

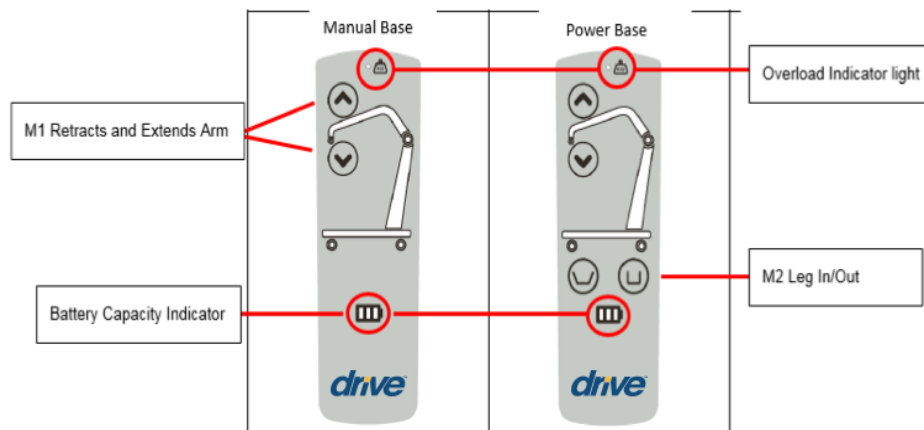

Emergency Stop

The red Emergency Stop Button is located on the top of the control box and is activated by pressing in. This will cut all power to the lift and only be reset by twisting the button counterclockwise and releasing.

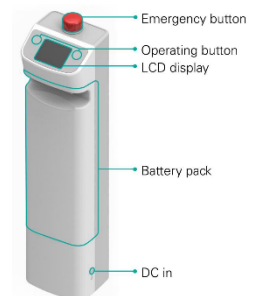

Mechanical Emergency Down

In the case of a complete electrical failure, the electrical actuator is fitted with a mechanical lowering red collar on top of actuator.

It is twisted by hand to activate lowering. A slow decent will commence.

Repeat this process until the patient has been safely lowered.



Mechanical lowering device



WARNING

If mechanical emergency lowering is used, the lift **MUST** be subsequently checked out by a competent person.

How to Lift the Patient

1. Instruct the patient to do the following:
 - Hold onto the vertical or horizontal handgrips which even is more comfortable on both sides of the lift.
 - Lean back into the sling.
2. Make sure of the following
 - Patient's knees are secure against the knee pad.
 - Patient's feet are positioned on the footplate.
 - The bottom edge of the sling is positioned on the lower back. Sling is at the base of the patient's spine.
 - The patient's arms are outside of the sling.
 - The rear casters are unlocked.
 - Make sure the legs are in the maximum open position.
3. If transferring from a wheelchair - Lock the wheel locks of the wheelchair.
4. Press the (M1) UP button to raise the patient above the surface (bed, wheelchair or commode) being transferred from. The patient should be elevated just high enough to clear the surface with their weight fully supported by the lift.

How to move the Patient

1. Using the push handle, move the lift away from the surface.
2. SLOWLY move the patient to the desired surface.

How to transfer the Patient to the desired surface

1. Have the wheelchair, bed or commode ready:
 - If transferring the patient to a wheelchair, move the wheelchair into position, lock the wheels of the wheelchair, position the patient over the wheelchair.
 - If transferring the patient to a bed, position the patient as far over the bed as possible.
 - If transferring the patient to a commode, position the patient over the commode.
2. Press the (M1) DOWN button and lower the patient onto the desired surface.
3. Lock the rear swivel casters of lift.
4. Unhook the sling from all attachment points on the lift.
5. Instruct the patient to lift their feet off of the footplate.
6. Remove the sling from around the patient.
7. Pull the lift away from the wheelchair, bed or commode.

SMART/SAFETY CONTROL MODULE

Redundant Control:

The Drive DeVilbiss Smart/Safety control module has two operation buttons and an LCD display on the top of control box (TC12), redundant controls for operation if the hand control becomes inoperable, battery and an emergency stop button.

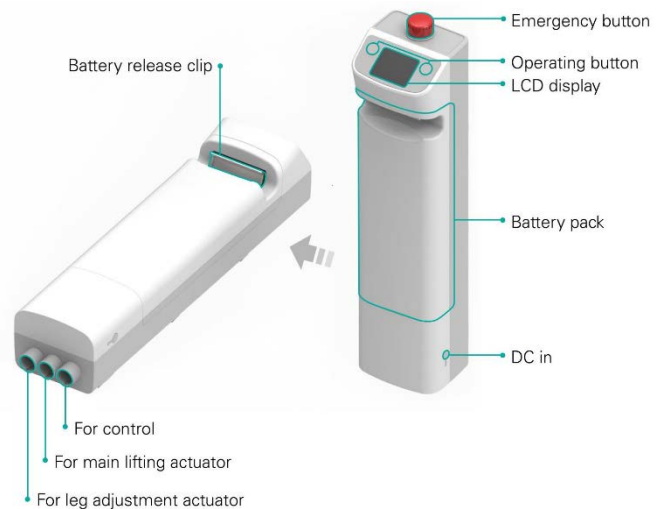



Main features:

- Raise/Lower, Legs open/close (with power base only).
- Visual battery indication with audible alarm when battery is at low capacity.
- Control box is equipped with overload protection for the lifting and leg spreading function.
- Emergency stop button disconnects power supply. Battery cannot be charged if emergency button is in lower.
- Charger is integrated in the control box or can be charged externally using the charging stand included.

Control Box (TC 12) User Guide

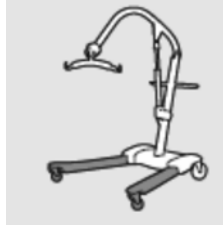
If you press either button (see Figure F) for less than 0.5 seconds, you can access the following screens:

<p>Raise or lower the lift.</p> 	<p>Opens/Closes the legs</p> 	<p>Remaining battery capacity.</p> 
---	--	--

1. Press the buttons to begin actuator extension and retraction.

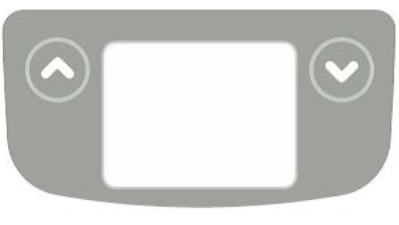
<p>Left button: Pressing the left button for more than 0.5 seconds will begin actuator extension.</p>	 <p>Figure F</p>	<p>Right button: Pressing the right button for more than 0.5 seconds will begin actuator retraction.</p>
---	--	--

The Smart/Safety Control Module

The Drive DeVilbiss Smart/Safety control module stores useful servicing information about the lift that can be recalled when required. This servicing information includes:

- Number of patient lift cycles
- Total work done by actuator

The Drive DeVilbiss Smart/Safety control module contains a microprocessor inside making it possible to read out service data via the on-board LCD screen. This information and setting can only be performed by using the Smart/Safety learning hand control (see Figure G)



Figure G

Features

- Work counter
- Intelligent cycle counter
- Service indicator
- Service interval indicator
- Overload information
- 3 step battery indicators

Benefits

- Improved safety for both patient and care giver
- Accurate service data available at the touch of a button
- Optimised product life time
- Ease of maintenance for engineers and service technicians

1. Getting Started

Connect the Smart/Safety learning hand control (see Figure G) for the setting mode.



Press  to start the learning mode.

2. Language Setting

We have six (6) standard options: English, Chinese, German, French, Japanese, and Spanish.

Press the  or  to select the language menu.



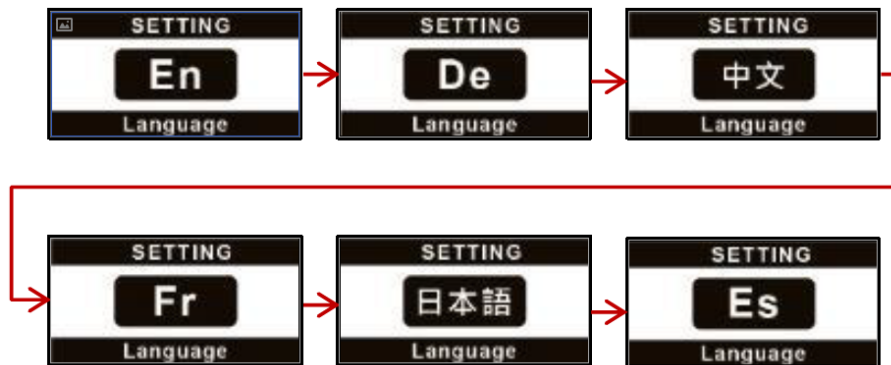

Press the  or  buttons to select the desired language or return to the main menu.





After selecting the desired language, press and hold the button  for 5 seconds to complete the process.

3. Maintenance Cycle Setting



Press the  or  buttons to select the maintenance cycle menu.



Press the  or  buttons to navigate to the maintenance cycle menu or return to the main menu.

Make your maintenance interval selection based on a time period or fixed number of cycles.





Press the  or  buttons to adjust the time period or cycles.

The time interval is adjustable in monthly increments and cycles are adjustable in increments of 1000.



If you don't want to set up the maintenance cycle, press the button  until the following symbol appears:



4. System Reset

Press the  or  to navigate to the reset menu.



Press the  or  buttons to select after maintenance or return to the main menu.

"After Maintenance" System Reset

Note: The maintenance interval settings are regulated by the number of cycles or months. An example is shown below.



Resetting the maintenance interval to 0

Before the reset –the display will appear similar to the images shown below.





To reset the maintenance interval, press and hold the button  for 5 seconds. When this process is completed, the values will be reset to zero.

After the reset is complete, the screen will appear similar to the images shown below. Note how the default maintenance time or cycle will start from zero (0).



Notifications

If the following notifications appear on the LCD display, please follow the procedures listed below to troubleshoot:

<p>Low battery capacity: Recharge battery. If it does not hold a proper charge, the battery will need to be replaced.</p>	 <p>The icon features the word "ATTENTION" in a dark grey bar at the top. Below it is a battery symbol with an exclamation mark inside. At the bottom, the text "Recharge Or Exchange" is displayed.</p>
<p>Overload alarm: Weight has exceeded the set maximum limit. Remove weight from the lift and retry.</p>	 <p>The icon features the word "ATTENTION" in a dark grey bar at the top. Below it is a weight symbol with "KG" inside. At the bottom, the text "Overloaded" is displayed.</p>
<p>Maintenance Required: When the M1 actuator usage is over the previously set maintenance time or cycle, this reminder triggers. Reset the whole system (refer to section 4-System Reset)</p>	 <p>The icon features the word "ATTENTION" in a dark grey bar at the top. Below it is a wrench symbol. At the bottom, the text "Maintenance Required" is displayed.</p>

BATTERY INFORMATION







WARNING

- If the lift is left in an environment where there are children or adults who have a reduced mental capacity present removal of the battery when the lift is not in use is recommended to avoid the potential of misuse or accidental activation.
- The only compatible battery is the BAT battery.
- Must follow the rated input voltage.
- Charge with certified charger from original manufacturer.
- Don't expose the battery to water or heat source.
- Recycle with certified depots. Batteries must be disposed of in accordance with local regulations.
- Repair by authorised maintenance centers.
- Never touch battery/charger terminals with any metal object.
- Keep the batteries fully charged. Place the battery on the charger whenever it is not in use. If it is convenient, place the battery on charger every night. The charger will not overcharge the battery.
- DO NOT leave the battery pack connected with the charger unplugged.
- DO NOT leave the charger plugged in with no battery connected.
- DO NOT charge batteries in wet environment or a bathroom or shower room.
- When the lift is low battery, the LED indicator on hand control will change from green to orange, the control box will give "beep" warning. At this moment, you should charge the battery immediately. Please note that a lifted patient cannot be lowered down when battery is out of power.
- If the lift is stored for a long period of time, the battery capacity can be harmed. Be sure to charge the battery every 24 hours or every 6 months at a minimum.
- The product should be charged continuously at least 24 hours under following circumstances:
 - First operation
 - Before long period storage without AC-in
 - First operation after long period storage

BATTERY CAPACITY

Status on Battery

LED indicator on handset will show you the status on battery

LED	Status	Voltage
 Orange	Low Battery Warning	24.0-24.5V
 Green	Low Battery	24.5-25V
 Green	Medium Battery	25-25.6V
 Green	High Battery	>25.6V

The batteries are protected from deep discharge by a lower voltage alarm. This will sound when the batteries need recharging and the hand control is being operated. It will not sound independently of the hand control being operated.

Note: DO NOT ignore this warning alarm. Complete the lifting operation and charge the battery pack immediately.

BATTERY CHARGING INSTRUCTIONS

When the power pack needs to be charged,

1. There are two possibilities to charge the battery:
 - Battery can be charged directly through control box, connect charger to control box DC jack then you can charge the battery. Please release **emergency button before charging. Charge will not be possible if emergency button is locked.**
 - Battery can also be charged on charging cradle, remove battery pack from the lift. The pack is retained by a simple latch at the top of the battery pack. Lift the latch and the battery pack will be released.
 - Fit the battery pack to the charging cradle, connect charger to the charging cradle DC jack, then you can charge that battery.
2. Charging is automatic and will fully charge the batteries over a period of approximately 14 hours.
3. To return the lift to service,
 - a) When battery is being charged on control box, simply unplug the charger.
 - b) Unplug the charger and remove the battery pack from the charging cradle. Fit the battery pack to the lift and make sure the latch holding the battery pack in place is fully engaged. "Click" in place.

CARE AND MAINTENANCE

CONTACT DETAIL

Only authorised service personnel or Drive DeVilbiss Healthcare Service Technicians should carry out repairs or service activities. Failure to do so may result in the manufacturer's warranty becoming void. Worn or malfunctioning parts must be replaced with original parts manufactured by Drive DeVilbiss Healthcare Ltd.

Contact your equipment provider or Drive DeVilbiss Healthcare if you need any help with installation, usage or maintenance of the product.

Drive DeVilbiss Healthcare Ltd.,
Halifax, West Yorkshire, HX2 9TN, Great Britain
Telephone:+44(0)845 0600333
Email : sales@drivedevilbiss.co.uk

CLEANING INSTRUCTIONS

- If used by more than one patient, clean between each use.
- Prior to cleaning unplug power supply cords
- Ensure all electrical parts (motors, control boxes, wires and handset) are not broken. Ensure that NO liquids enter electrical components.
- DO NOT clean the lift or any component parts under running water or submerge in water.
- DO NOT use power wash or steam cleaner for any parts
- Ensure all parts are dry before use or storing

GENERAL CLEANING

- Remove any debris and wipe down with a clean cloth moistened with a mild detergent diluted with warm water (max temperature 43°C).
- Wipe surfaces with clean water and a clean cloth and allow to fully dry before use.
- Do not use harsh detergents and do not clean under running water.

DECONTAMINATION (Whenever necessary; to be performed by a competent person).

- Remove any debris and mop up any fluid with paper towels.
- Wipe surfaces using clean water.
- Wipe down with a 0.1% Chlorine solution (1,000ppm)
- Wipe surfaces with clean water and a clean cloth and allow to fully dry before use.
- In cases of blood spills or other bodily fluids it is recommended that a 1% Chlorine solution (10,000ppm) is used instead.
- Suitable protective clothing must be worn when handling chlorine solutions.

NOTE: This Lift is NOT compatible with wash down tunnels.

MAINTENANCE SCHEDULE



WARNING

- All Drive DeVilbiss products are designed for minimum maintenance, however some safety checks and procedures are required. A schedule of DAILY tasks is detailed below. Regular checks and a yearly service, inspection and test will ensure a lift is kept in optimum safe working condition. A list of spare parts is available upon request.
- Drive DeVilbiss Healthcare recommends regular inspection and maintenance. Please refer to the chart below.
- Only authorised service personnel or Drive DeVilbiss Healthcare Service Technicians should carry out repairs or service activities. Failure to do so may result in the manufacturer's warranty becoming void. Worn or malfunctioning parts must be replaced with original parts manufactured by Drive DeVilbiss Healthcare Ltd.

Item	Pre-Delivery	Daily	6 month	Annual
PRE-DELIVERY				
<ul style="list-style-type: none"> • Confirm all components are included. • Inspect parts for possible damage in transit. 	<ul style="list-style-type: none"> ✓ ✓ 			
COMPLETE LIFT				
<ul style="list-style-type: none"> • General inspection of Lift. Visually inspect the patient lift for external damage or wear. Scratches and chips. 	<ul style="list-style-type: none"> ✓ 	<ul style="list-style-type: none"> ✓ 	<ul style="list-style-type: none"> ✓ 	<ul style="list-style-type: none"> ✓
BASE AND CASTORS				
<ul style="list-style-type: none"> • Inspect for missing hardware. • Base opens/closes with ease. • Inspect castors and axle bolts for tightness. Make sure tightly attached to legs. • Inspect castors for smooth swivel and roll. • Check castor brakes operate efficiently. • Overhaul castors and repack with grease. • Check tightness of bolt in leg bushes. • Check linkages are secure in leg adjuster ball joints. 	<ul style="list-style-type: none"> ✓ ✓ ✓ ✓ ✓ ✓ ✓ 		<ul style="list-style-type: none"> ✓ ✓ ✓ ✓ ✓ ✓ ✓ 	<ul style="list-style-type: none"> ✓ ✓ ✓ ✓ ✓ ✓ ✓
MAST				
<ul style="list-style-type: none"> • Mast MUST be securely assembled to boom. • Inspect for bends or deflections. • Check Sling hooks for wear or deflection. 	<ul style="list-style-type: none"> ✓ ✓ ✓ 	<ul style="list-style-type: none"> ✓ 	<ul style="list-style-type: none"> ✓ ✓ ✓ 	<ul style="list-style-type: none"> ✓ ✓ ✓
ELECTRIC ACTUATOR ASSEMBLY				
<ul style="list-style-type: none"> • Check hand control and cycle to ensure smooth quiet operation. Lift adjustment on all Lifters. Width also for those with electric leg adjustment. • Emergency lowering function (electric and mechanical) • Check for wear or deterioration. • Inspect hardware on mast and boom. • Remove dust and dirt from actuator with cloth. 	<ul style="list-style-type: none"> ✓ ✓ ✓ ✓ 	<ul style="list-style-type: none"> ✓ ✓ 	<ul style="list-style-type: none"> ✓ ✓ ✓ ✓ 	<ul style="list-style-type: none"> ✓ ✓ ✓ ✓
BOOM				
<ul style="list-style-type: none"> • Check all hardware and swivel bar supports. • Inspect for bends or deflections • Inspect bolted joints of boom for wear • Inspect to ensure that the boom is centered between the base legs. 	<ul style="list-style-type: none"> ✓ ✓ ✓ ✓ 		<ul style="list-style-type: none"> ✓ ✓ ✓ ✓ 	<ul style="list-style-type: none"> ✓ ✓ ✓ ✓

Item	Pre-Delivery	Daily	6 month	Annual
SLINGS AND HARDWARE				
<ul style="list-style-type: none"> CHECK ALL SLING ATTACHMENTS each time it is used to ensure proper connection and patient safety. Inspect sling material for wear. Inspect straps for wear. 	√	√	√	√
CLEANING				
<ul style="list-style-type: none"> Whenever necessary. Clean the lift per CLEANING INSTRUCTIONS in the CARE AND MAINTENANCE section of this manual 		√	√	√
SHIFTER HANDLE (Manual Leg Adjustment Only)				
<ul style="list-style-type: none"> Operates smoothly. Locks adjustable base whenever engaged. 	√		√	√
ON COMPLETION OF CHECK or SERVICE				
<ul style="list-style-type: none"> Arrange repair/replacement of any faulty parts. 	√	√	√	√

SERVICING



WARNING

The power system includes battery, charger, handset, actuators and control box, they are not to be opened by unauthorised personnel,

Servicing should not be conducted while in use with a patient.

ACTUATORS WIRING

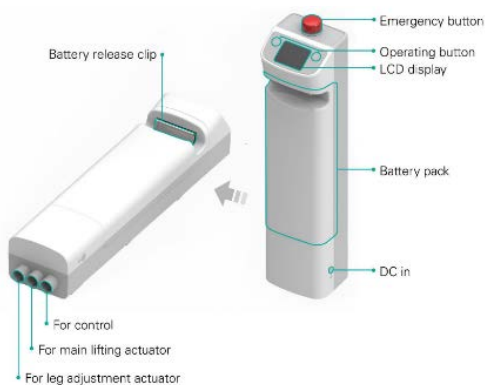

- CH1: Control box.
- CH2: Actuator for lifting.
- CH3: Actuator for leg adjustment.
- CH4: Wall mount charger /Charging cradle

ROUTING LAYOUT





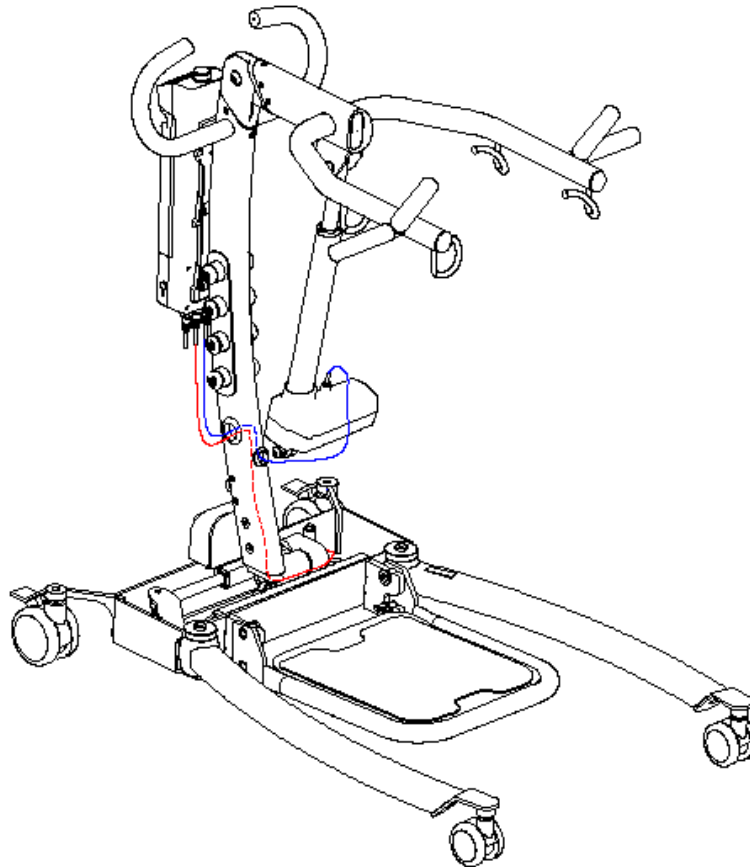

WARNING

When routing cables in the medical lift, precautions shall be taken to avoid squeezing between parts of the lift.

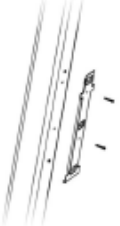

REPLACING CONTROL /BATTERY PACK

<p>1. Install the bracket on the Lift Mast</p> 	<p>2. Install the control box on the bracket</p> 	<p>3. Make sure all fasteners are tightened properly</p> 
<p>4. Install the battery</p> 	<p>5. Installation is completed</p> 	

TROUBLESHOOTING GUIDE



WARNING

Before doing any repairs or maintenance to the lift frame, read all instructions, cautions, and warnings. Repairs should be done by a skilled technician.

Normal Symptom	Possible Cause	Solutions
Patient Lift feels loose.	<ul style="list-style-type: none"> • Mast/Base joint loose. • Tie - Rods are loose. 	<ul style="list-style-type: none"> • Refer to ASSEMBLY section in this manual. • Check the Base Adjustment <ol style="list-style-type: none"> 1. Check the squareness of the legs when in the closed position. 2. Place a square on the inside of the legs and base to determine the 90° alignment. 3. Adjust the linkage rods until 90° alignment achieved
Boom will not lower in upper most position.	<ul style="list-style-type: none"> • Boom requires a minimum weight load to lower from the upper most position. 	<ul style="list-style-type: none"> • Pull down slightly on the lift arm.
Power indicator is not on	<ul style="list-style-type: none"> • Malfunction on handset • Battery is out • Battery is damaged • Control box is damaged 	<ul style="list-style-type: none"> • Replace handset • Charge battery • Replace battery • Replace control box
Power indicator is on, actuator does not run and control box has clicking sound	<ul style="list-style-type: none"> • Actuator connector is damaged • Actuator is not connected • Actuator is damaged • Control box is damaged 	<ul style="list-style-type: none"> • Replace actuator • Connect actuator to control box • Replace actuator • Replace control box
Power indicator is on, actuator does not run and control box has no clicking sound	<ul style="list-style-type: none"> • Control box has malfunctioned • Handset has malfunctioned • Handset is not connected • Emergency button is pressed • Control box is charging 	<ul style="list-style-type: none"> • Replace control box • Replace handset • Connect handset • Reset/release emergency button • Unplug charger
Control box is not responsive with no indicator and no movement from actuator	<ul style="list-style-type: none"> • Battery is completely discharged • Battery is damaged 	<ul style="list-style-type: none"> • Charge the battery • Replace battery

<p>Actuator could only operate in one direction</p>	<ul style="list-style-type: none"> • Handset has malfunctioned • Control box has malfunctioned 	<ul style="list-style-type: none"> • Replace handset • Replace control box
<p>After pressing handset buttons, there is a buzzer sound from control box and actuator is not moving</p>	<ul style="list-style-type: none"> • The object on device is overweight • Actuator is damaged 	<ul style="list-style-type: none"> • Remove/reduce weight on device • Replace actuator

WARRANTY

The Rise Sit to Stand PR51STSP is guaranteed for a 3 year period from the date of production. This guarantee is against defects in materials and craftsmanship, under normal use and service.

This 3-year warranty includes electrical and mechanical parts. Steel structural components are covered under the 10-year warranty from the date of production.

- ✓ 10 year warranty on structural steel frame.
 - ✓ 3 year warranty on electrical and mechanical parts
 - ✓ 1 year warranty on battery and all other parts and components.
- Rise Sit to Stand PR51STSP should only be used for its intended purpose and must be maintained and serviced in accordance with the instructions contained in this Owner's Manual.
 - This warranty will not apply if damage or mechanical failure is caused by abuse, improper assembly/use/cleaning/repair, accident, negligence, unauthorised alteration, or use in inappropriate environmental conditions, or failure to maintain the product consistent with user and service instructions.
 - Any change, adjustments, or repair not performed by a Drive DeVilbiss Healthcare or an Authorised Distributor or technician, will void the warranty.
 - This warranty is extended only to the original owner who purchased this product new and unused from Drive DeVilbiss Healthcare or a Drive DeVilbiss Healthcare Authorised dealer/Distributor. Warranty is not extended and is not transferable or assignable to any subsequent purchaser or future owners.
 - Drive DeVilbiss Healthcare's liability shall not exceed the original purchase price of this product.
 - Any Repair work or replacement components provided shall not extend the warranty beyond the original warranty period.
 - Request for Warranty coverage must be accompanied by valid serial number from the lift. Coverage is void if serial number has been removed, defaced, or altered.

PARTS

Warranty replacement parts are covered by the warranty until the product's 3- year warranty period expires. For warranty replacement, Drive DeVilbiss Healthcare requests that broken parts be sent back to them for investigation. A credit will be issued only after the inspection and determination of cause.

SERVICE

Contact Drive DeVilbiss Healthcare service department if you need further help.

This warranty is extended to the original purchaser of the equipment.

SALES AND SERVICE

Contact Drive DeVilbiss Healthcare if you need any help with installation, usage or maintenance of the product.

Drive DeVilbiss Healthcare Ltd.,

Halifax, West Yorkshire HX2 9TN Great Britain

Telephone:+44(0)845 0600333

Email : sales@drivedevilbiss.co.uk

[END OF LIFE DISPOSAL]



- When the frame, any associated accessories and / or the electrical system has come to the end of its useful life, follow local recycling and W.E.E.E (Waste Electrical and Electronic Equipment) policies – For further information contact Drive DeVilbiss Healthcare Ltd.
- The electrical system is not to be disposed of in general municipal waste. Some of the electrical components could be harmful to the environment and where viable the components can be recovered and reused / recycled.
- The steel and plastic components are also to be separated and disposed of following local recycling policy as these can also be recovered and recycled.
- Decontaminate product before disposal to avoid risk of cross contamination.

Applicable Standard

The product has been tested to meet the following international standards:

- EN60601-1-2/IEC60601-1-2: Medical electrical equipment - Part 1-2: General requirements for basic safety and essential performance - Collateral Standard: Electromagnetic disturbances - Requirements and tests
- IEC 60601-1 Medical electrical equipment - Part 1: General requirements for basic safety and essential performance
- IEC 60601-1-6 Medical electrical equipment Part 1-6 General requirements for safety - Collateral Standard: Usability
- IEC 60601-1-11 Medical electrical equipment – Part 1-11: General requirements for basic safety and essential performance – Collateral Standard: Requirements for medical electrical equipment and medical electrical systems used in the home healthcare environment
- EN ISO 10535 Hoists for the transfer of disabled persons Requirements and test methods
- EN12182: Assistive products for persons with disability – General requirements and test method
- ISO 10993-10: Skin Irritation Test
- ISO 10993-10: Skin Sensitization Test
- ISO 10993-5: In Vitro Cytotoxicity Test



Xiamen World Gear Sports Goods Co., Ltd
No.27-29 North 2nd Road, Xinglin, Jimei District Xiamen,361022, China

UKRP

SHARE INFO LTD
3rd Floor, Office C, Townend House, Park Street, Walsall, West
Midlands, WS1 1NS, United Kingdom



Share Info GmbH
Heerdter Lohweg 83, 40549 Düsseldorf Germany



Drive DeVilbiss Healthcare Ltd.,
Halifax, West Yorkshire, HX2 9TN
Great Britain
sales@drivedevilbiss.co.uk

Drive DeVilbiss Sidhil Ltd.
4 Trench Road, Mallusk, Newtownabbey,
BT36 4TY, Northern Ireland